



The compact and sleek PEGASUS is perfect for a minimalist approach to workstation design and connectivity within the workspace.

PEGASUS takes up a minimum of space yet used in conjunction with the OE QIKFIT range, PEGASUS provides a comprehensive solution for power, data and AV connectivity at the workstation.

PEGASUS delivers a cost effective solution.

Standard colours: White Powdercoat body - white or grey fascias. Other colours available on request.



Common Modular Components*



QF35 2GPO 1UFA+C



QF25 2GPO



Range of QF5 Tiles to provide Data and AV solutions

Expanded View Pegasus QF35

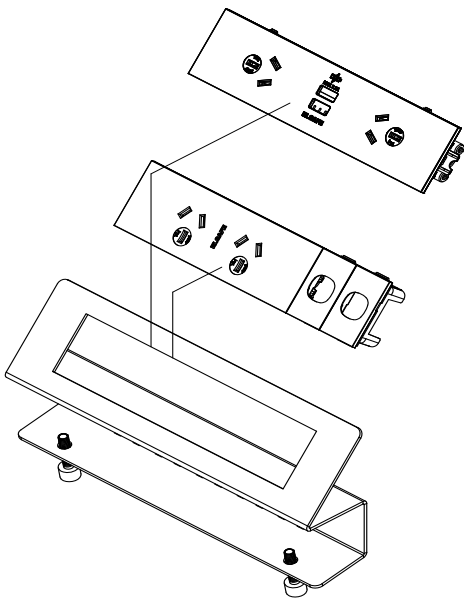

Pegasus Dimensions QF35

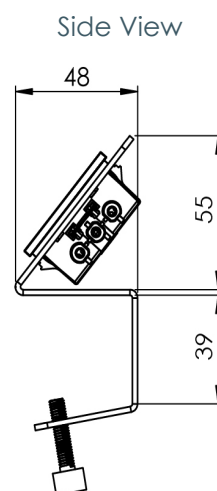
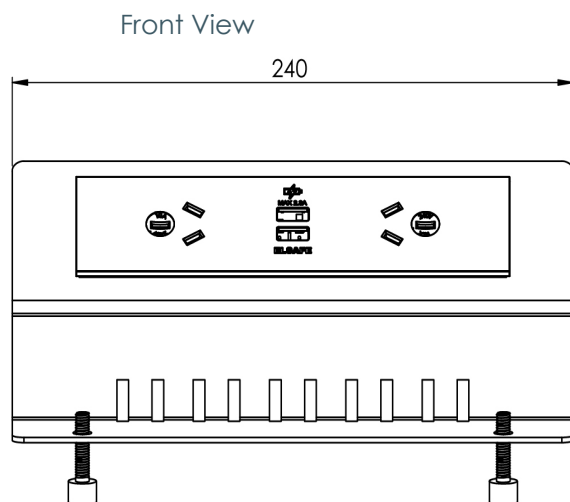

Features

Configuration:

Power only / Data only / Combined (Power, USB Charging & Data)

Insulation:

Reinforced insulation

Soft Wiring (Power):

Power hardwired to Wieland GST connector allows starter cables to be changed to suit requirements, especially useful during moves and changes (CHURN).

Soft Wired (Data):

As well as soft wired power, PEGASUS can be fitted with soft wired data.

Testing:

100% testing - continuity, polarity, insulation and earth.

Fixing Options:

Standard Desk Bracket - tighten by hand from under desk. Table thickness 15-35mm.

Pegasus is designed and intended for commercial use.